



**SCHEDA TECNICA**  
**SISTEMA DI APERTURA KRABY RIALZA**

## KRABY RIALZA

- Sistema adatto per le aperture a rialza (verso l'alto).
- Disponibile in due versioni: soft-stop e frizionata.
- Nella versione soft-stop, l'anta viene spinta in modo graduale e continuo fino alla sua massima apertura.
- Nella versione frizionata, l'anta può essere frenata in fase di apertura e chiusura nella sua posizione desiderata.
- Grazie alla sua regolazione si possono allineare ante adiacenti.



### DIMENSIONI

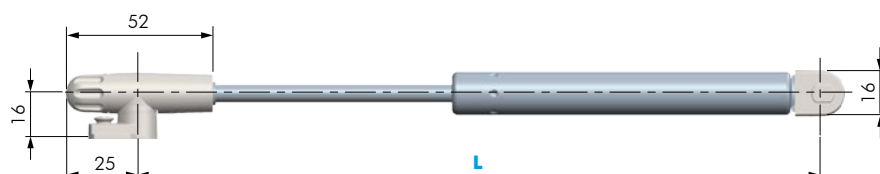

DESCRIZIONE	L	NEWTON	
ASTA KRABY RIALZA FRIZIONATA	164	45	
		60	
		90	
	244	45	
		60	
		90	
		120	
	355	45	
		60	
		90	
		120	
	480	45	
60			
90			
120			
ASTA KRABY RIALZA SOFT - STOP		164	50
			80
	120		
	244	50	
		80	
		100	
		120	
	355	50	
		80	
		100	
		120	

### FORATURE

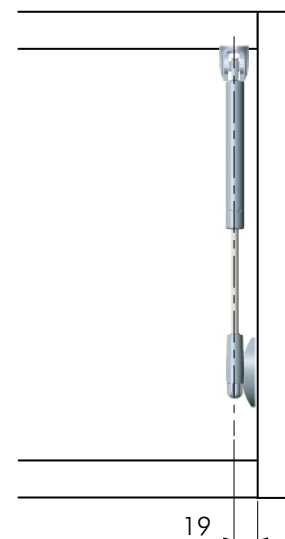
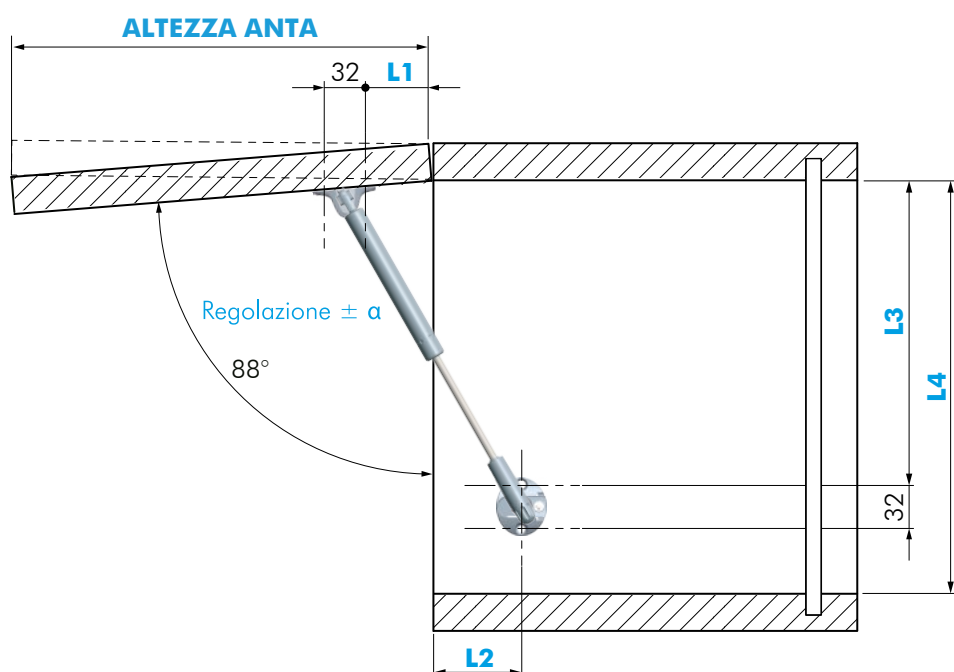

ASTA	CERNIERA	APERTURA	L1	L2	L3	L4 MIN	$\alpha$	CRICCHETTO
L164	STANDARD CON O SENZA MOLLA	MANIGLIA	31	37	148	193	85° +13° -7°	SENZA MOLLA USARE K LOCK
	STANDARD	AUTOMATICA	25	60	135	185	88° +17° -7°	K PUSH TECH MAGNETE
L244	STANDARD CON O SENZA MOLLA	MANIGLIA	68	37	224	270	85° +5° -6°	SENZA MOLLA USARE K LOCK
	STANDARD	AUTOMATICA	55	60	210	260	88° +12° -3°	K PUSH TECH MAGNETE
L355	STANDARD CON O SENZA MOLLA	MANIGLIA	119	37	329	374	85° +2° -6°	SENZA MOLLA USARE K LOCK
	STANDARD	AUTOMATICA	105	60	315	365	88° +5° -3°	K PUSH TECH MAGNETE
L480	STANDARD CON O SENZA MOLLA	MANIGLIA	174	37	449	494	85° +3° -2°	SENZA MOLLA USARE K LOCK

Posizione A - Chiusura normale

Posizione B - Chiusura morbida

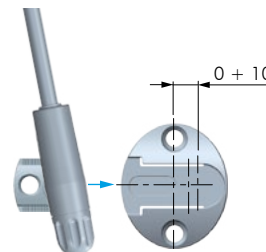
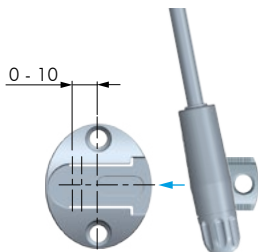
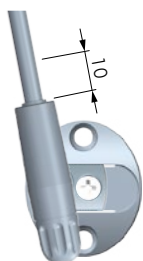

## INSTALLAZIONE

### ANTA IN LEGNO

STEP 1 - Innesto anta

STEP 2 - Innesto fianco

STEP 3 - Apertura soft-stop

STEP 4 - Apertura frizionata

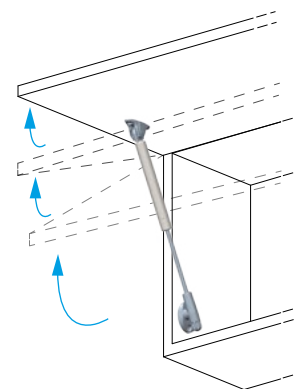
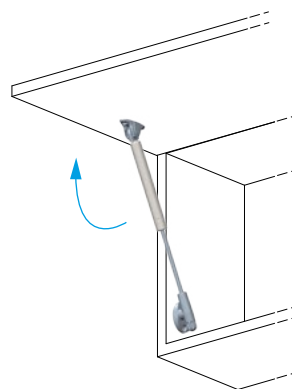
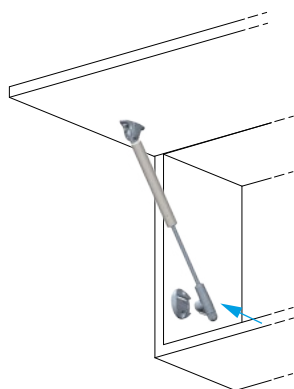
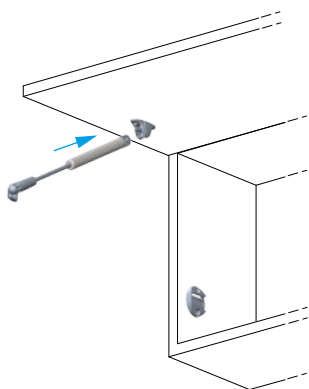

### ANTA CON TELAIO IN ALLUMINIO

STEP 1 - Innesto anta

STEP 2 - Innesto fianco

STEP 3 - Apertura soft-stop

STEP 4 - Apertura frizionata

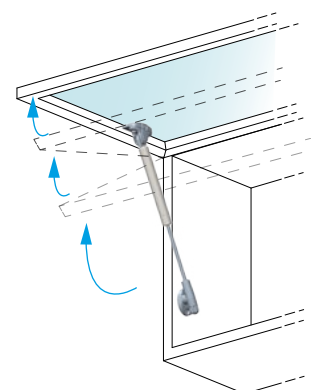
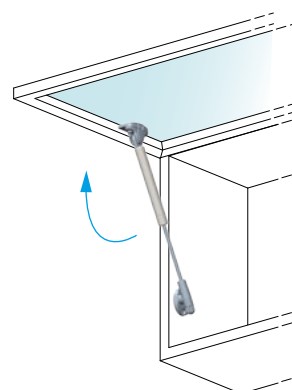
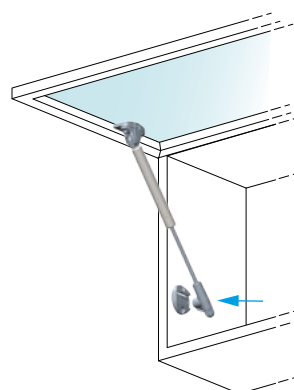
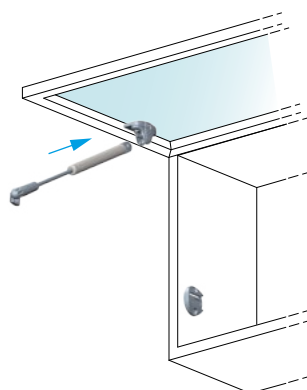

**L164 - SCELTA FORZE**

ALTEZZA ANTA MM	VERSIONE KRABY	PESO ANTA KG									
		1	2	3	4	5	6	7	8	9	10
230-274	SOFT-STOP	1x80N	2x80N	2x120N	3x120N	4x120N					
	FRIZIONATA	1x45N	2x45N	2x60N	3x60N						
275-325	SOFT-STOP	1x80N	2x80N	2x120N	3x120N	4x120N					
	FRIZIONATA	1x60N	2x45N	2x60N	3x60N	4x60N					

**L244 - SCELTA FORZE**

ALTEZZA ANTA MM	VERSIONE KRABY	PESO ANTA KG												
		1	2	3	4	5	6	7	8	9	10	11	12	13
300-324	SOFT-STOP	1x80N	2x50N	2x80N	2x100N	2x120N	2x140N	2x160N*	2x180N*	2x240N*				
	FRIZIONATA	1x45N	1x60N	2x45N	2x60N	2x90N	2x120N	2x160N*	2x180N*	2x240N*				
325-374	SOFT-STOP	1x80N	2x50N	2x80N	2x100N	2x120N	2x140N	2x160N*	2x180N*	2x240N*				
	FRIZIONATA	1x45N	1x60N	2x45N	2x60N	2x90N	2x120N	2x160N*	2x180N*	2x240N*				
375-424	SOFT-STOP	1x80N	2x50N	2x80N	2x100N	2x120N	2x140N	2x160N*	2x180N*	2x240N*				
	FRIZIONATA	1x45N	1x60N	2x45N	2x60N	2x90N	2x120N	2x160N*	2x180N*	2x240N*				
425-474	SOFT-STOP	2x50N	2x80N	2x100N	2x120N	2x140N	2x160N*	2x180N*	3x160N*					
	FRIZIONATA	1x60N	2x45N	2x60N	2x90N	2x120N	2x160N*	2x180N*	3x90N					
475-524	SOFT-STOP	2x80N	2x100N	2x120N	2x140N	2x160N*	2x180N*	3x160N*						
	FRIZIONATA	2x45N	2x60N	2x90N	2x120N	3x90N	3x120N							

**L355 - SCELTA FORZE**

ALTEZZA ANTA MM	VERSIONE KRABY	PESO ANTA KG												
		1	2	3	4	5	6	7	8	9	10	11	12	13
400-424	SOFT-STOP	1x80N	2x50N	2x80N	2x100N	2x120N	2x160N							
	FRIZIONATA	2x45N	2x60N	2x90N	2x120N	2x160N	2x200N							
425-474	SOFT-STOP	1x80N	2x50N	2x80N	2x100N	2x120N	2x160N	2x180N	2x200N					
	FRIZIONATA	2x45N	2x60N	2x90N	2x120N	2x160N	2x200N							
475-524	SOFT-STOP	1x80N	2x50N	2x80N	2x100N	2x120N	2x160N	2x180N	2x200N					
	FRIZIONATA	2x45N	2x60N	2x90N	2x120N	2x160N	2x200N							
525-574	SOFT-STOP	1x80N	2x50N	2x80N	2x100N	2x100N	2x160N	2x180N	2x200N					
	FRIZIONATA	2x45N	2x60N	2x90N	2x120N	2x160N	2x200N							
575-624	SOFT-STOP	2x50N	2x80N	2x100N	2x120N	2x160N	2x180N	2x200N						
	FRIZIONATA	2x45N	2x60N	2x90N	2x120N	2x160N	2x200N							
625-700	SOFT-STOP	2x50N	2x80N	2x100N	2x120N	2x160N	2x180N	2x200N						
	FRIZIONATA	2x45N	2x60N	2x90N	2x120N	2x160N	2x200N							

**L480 - SCELTA FORZE**

ALTEZZA ANTA MM	VERSIONE KRABY	PESO ANTA KG														
		1	2	3	4	5	6	7	8	9	10	11	12	13	14	15
521-550	SOFT-STOP	-	1x80N	2x50N o 1x100N	2x80N	2x100N	2x120N	-								
	FRIZIONATA	-	1x45N	1x60N	1x90N o 2x45N	2x60N	2x90N	2x120N								
551-600	SOFT-STOP	-	1x80N	2x50N o 1x100N	2x80N	2x100N	2x120N	-								
	FRIZIONATA	-	1x45N	1x60N	1x90N o 2x45N	2x60N	2x90N	2x120N								
601-650	SOFT-STOP	-	2x50N o 1x100N	2x80N	2x100N	2x120N	-									
	FRIZIONATA	-	1x45N	1x60N	1x90N o 2x45N	2x60N	2x90N	2x120N								
651-700	SOFT-STOP	-	2x50N o 1x100N	2x80N	2x100N	2x120N	-									
	FRIZIONATA	-	1x60N	1x90N o 2x45N	2x60N	2x90N	2x120N									

\*FORZE DISPONIBILI SU RICHIESTA.

**FERRAMENTA LIVENZA SRL**

SEDE: viale L. Zanussi, 21 | 33070 Maron di Brugnera (PN)

T: +39 0434 616211 | F: +39 0434 616218

E: [info@ferramentalivezza.it](mailto:info@ferramentalivezza.it)

FILIALE: via R. Serra, 74 | 61122 Pesaro (PU)

T: +39 0721 283531 | F: +39 0721 280175

**[www.ferramentalivezza.it](http://www.ferramentalivezza.it)**